

# AIR CONTROL



## PROPORTIONAL AIR CONTROL 1 SECTION

Hyva

type :  
option :

proportional air control 1 section  
fixed tipping position

page # 1 / 2

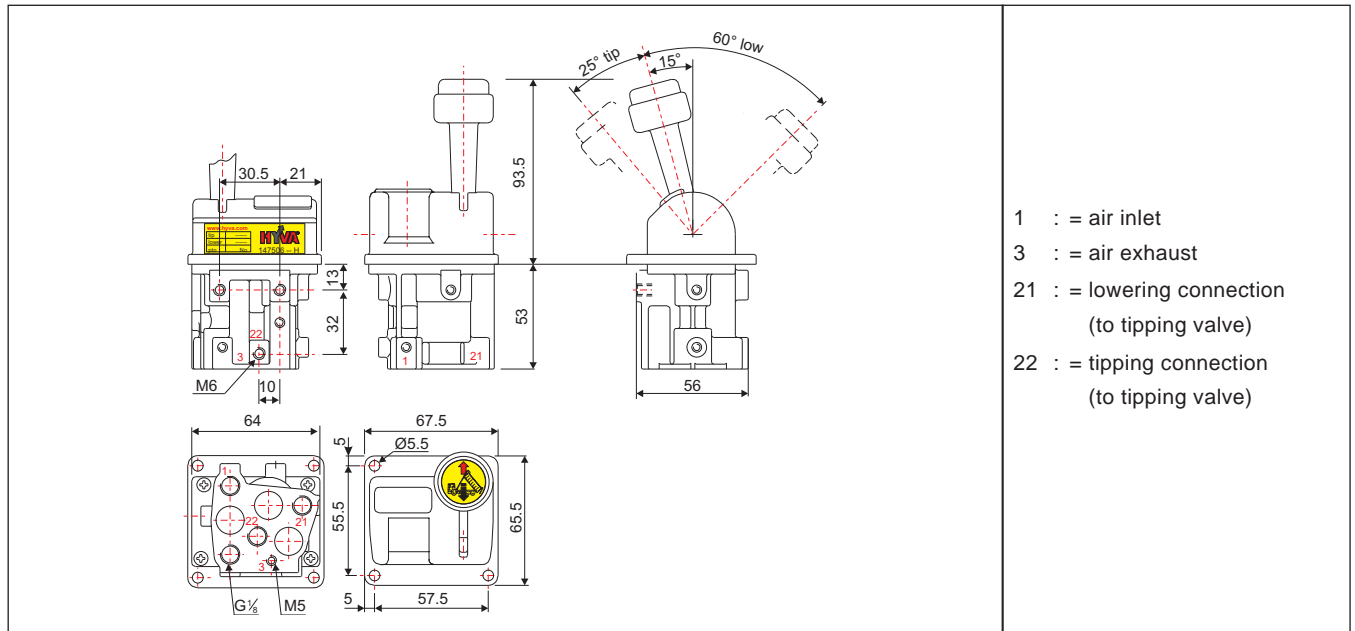

### mounting of the air control

- When the air control is mounted next to the drivers seat a strong support should be used.  
Available supports are:
  - 092 32 002 for on-seat mounting
  - 092 05 002 for on-floor mounting
- Use always rubber grommets to protect air tubes and to prevent that dust and water enters the cabin.
- For trouble free life of the entire pneumatic system the air system must be free from water.
- The air control should be mounted in such a way that:
  - 1 it is easy to reach by the operator.
  - 2 it is no obstacle when entering or leaving the cabin.
  - 3 it is clear from any moving parts such as drivers seat and closed door.
- The air exhaust connection must be brought outside the cabin to prevent air entering the cabin, which gives the following disadvantages:
  - 1 noise
  - 2 blown up sand and dust
  - 3 when alcohol is used to prevent the pneumatic system against frost the alcohol vapour will enter the cabin
- Make sure that air tubes:
  - 1 are not too close to sharp objects.
  - 2 are clear from moving parts.
  - 3 are clear from exhaust and compressor lines.
  - 4 can not get kinked.
  - 5 are not too long.

**note:** The air supply must always be tapped off from a accessory air tank or auxiliary valve and the pneumatic system must be protected with a charging valve.  
( see guide - lines from truck manufacturer )

For operation of the air control see the Hyva 'operation and maintenance instructions'

### 1 section air control range

part no.	description	qty
147 50 665 H	control pneumatic - 1 - TF/LF	1
147 50 667 H	control pneumatic - 1 - TS/LF	1

#### Explanation of codes:

- 1 = control has 1 section
- TF = lever is fixed in tipping end position
- TS = lever has a spring return in tip position
- LF = lever is fixed in lowering end position

### general info

- When used with a compatible tipping valve with proportional lowering, the speed of descent of the body can be regulated by the proportional movement of the air control lever.
- The functions of Hyva air controls are clearly indicated on the type plate.

### specifications

- Max. pressure = 12 bar
- Min. pressure = 5 bar
- Max. temperature = + 80°
- Min temperature = - 40°
- Connections 1, 21 & 22 = G1/8"
- Connection 3 = M5
- Mounting holes = M6

# AIR CONTROL

## PROPORTIONAL AIR CONTROL 1 SECTION

<b>Hyva</b>	<b>type :</b>	<b>proportional air control 1 section</b>
<b>page # 2 / 2</b>	<b>option :</b>	<b>fixed tipping position</b>

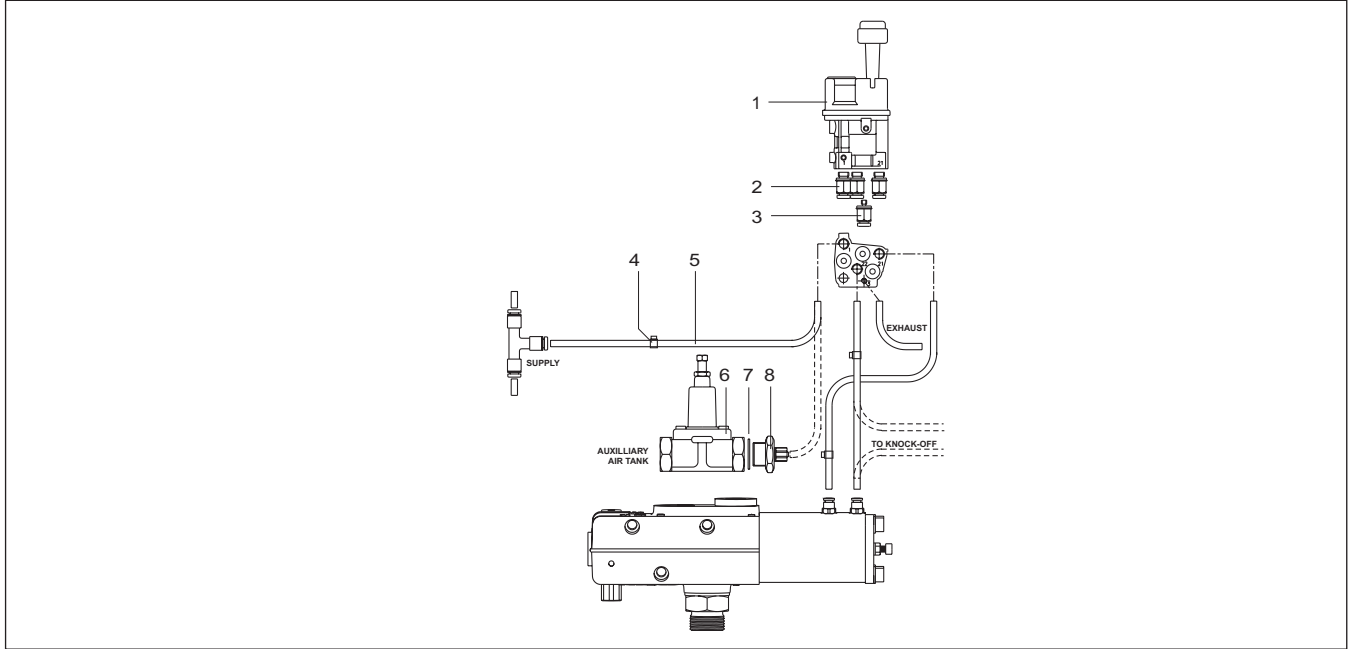

### Order possibilities of the air control

pos.	part no.	description	qty.
1	147 50 644 H	control pneumatic - 1 - TF/LF	1
	147 50 646 H	control pneumatic - 1 - TS/LF	1
2,3,4,5	147 52 141 K	air kit valve	1
2	148 10 517	coupling for air control G1/8"	3
3	148 10 515	coupling for air control M5	1
4	148 75 500	air tube tie	4
5	148 75 007	air tube 6x4 ( 20 m )	1
6,7,8	147 54 010	charging valve kit	optional 1
7	148 84 501	washer 27x22	optional 1
8	148 11 005	coupling m 22-6 mm	optional 1
	092 32 002	mounting support	optional 1
	092 05 002	mounting sup. (angled)	optional 1

### Pneumatic symbol

