

We keep you moving

**Gardner
Denver**

TRANSPORT SOLUTIONS

Oil Free Screw Compressors XK Range



DRUM
XK|12 XK|18



Advantages at a Glance

Ease of Fitting

With dual input drive rotation, multi outlet port positions, direct PTO input drive speed range and slim profile, the machine is designed to fit within the chassis. Purpose designed ancillaries including mounting brackets, absorptive or reactive silencers and discharge cooler/inlet filter modules provided separately or in several ready-to-fit packages all add to the ease of fitting.

Robust Design

Designed exclusively for the truck market and utilising the 40 years of experience in manufacturing equipment for tank trucks, the XK range gives the robustness required for the truck operation under all conditions.

	XK-12	XK-18
Ambient Temperature Range	-40° – +50° C	-40° – +50° C
Maximum Inlet Depression	100 mbar	100 mbar

Low Discharge Temperature

The special design of the 5-3 rotor configuration and porting results in high efficiency giving the machines the lowest outlet temperatures of any comparable truck mounted compressor. The necessity for air discharge coolers is significantly reduced.

	XK-12	XK-18
Input Speed Range	1,000 – 1,600 rpm	1,000 – 1,800 rpm
Temperature Rise at 1 bar g	107 – 112° C	102 – 113° C
Temperature Rise at 2 bar g	164 – 167° C	156 – 162° C

Packages

The XK machines are available in multiple packages to suit different markets, vehicles and customers with integral or remote coolers, reactive or absorptive silencers.

Value for Money

The XK machines are, by design, the most efficient on the market which is borne out by the low power required for the airflow and pressure produced. Cubic metre for cubic metre, these are the lowest operating cost machines on the market. No extra drive ancillaries, e.g. step-ups, oil coolers or other hidden costs are required with the machines.

Flexibility

Best in class flow range, best in class pressure range. The machines will operate continuously at any pressure and flow within the ranges given allowing all common powders, granules, pellets and feeds to be discharged at optimum rates.

	XK-12	XK-18
Input Speed Range	1,000 – 1,600 rpm	1,000 – 1,800 rpm
Discharge flow 1 bar g	390 – 665 m ³ /h	541 – 1,105 m ³ /h
Discharge flow 2 bar g	352 – 625 m ³ /h	508 – 1,068 m ³ /h

Reliability

Unprecedented design and testing regime (PAS) provides assured reliability.

Lightweight

Utilising state of the art 3D modelling design and analysis equipment together with modern materials the XK range is the best in class for weight per cubic meter of air delivered.

Best in Class Oil-free Compressors

XK | 12

The XK-12 is a robust, medium flow, oil-free, contactless, low maintenance screw compressor designed for the contaminant free discharge of dense bulk powder products (e.g. cement, flour and lime), usually at 1.5 – 2.0 bar g (at the tank) and at up to 2.5 bar g.

XK | 18

The XK-18 is a robust, high flow, oil-free, contactless, low maintenance screw compressor designed for the contaminant free discharge of a wide range of product types including granular, pellet, random particle products at 1 – 1.5 bar g (e.g. sugar, plastic granules and animal feeds) with a higher pressure availability.



XK-12 Compressor

XK|12



Maximum discharge pressure: 2.5 bar g
Discharge flow rate 330 – 610 m³/h at 2.5 bar g

Specification

General design

The XK-12 is an oil-free screw compressor comprising synchronised screw rotors, combined main body step up gearcase assembly and inlet bearing carrier.

Mounting

The compact shape and size of the XK-12 make it ideal for mounting inside the chassis on most vehicles to enable low cost direct PTO driving.

A through shaft allows CW or ACW input drive rotation with mounting points on either side of the machine to provide further flexibility.

Drive Options

Prop. shaft drive: Direct from a vehicle PTO

Hydraulic drive: Several drives can be offered depending on the application

Electric motor: Packages on base frames utilising the high input speed version

Engine drive: Packages on base frames utilising the high input speed version

The Standard Package

The standard package consists of the following equipment:

- Basic XK-12 machine and mounting flange pack
- Inlet kit including a cyclonic inlet filter
- Commissioning filter
- Relief valve
- Check valve and flange pack
- Outlet silencer – reactive or absorptive
- Torque limiting coupling

Note: The machine is also available in a high input speed version (1,800 – 2,900 rpm) for diesel engine and electric motor drives.

Optional Ancillaries

- Various drive flanges
- Absorptive or reactive silencer
- Various flange pack materials
- Remote air cooler pack
- Delivery filter

XK-12 Discharge Flow and Input Power

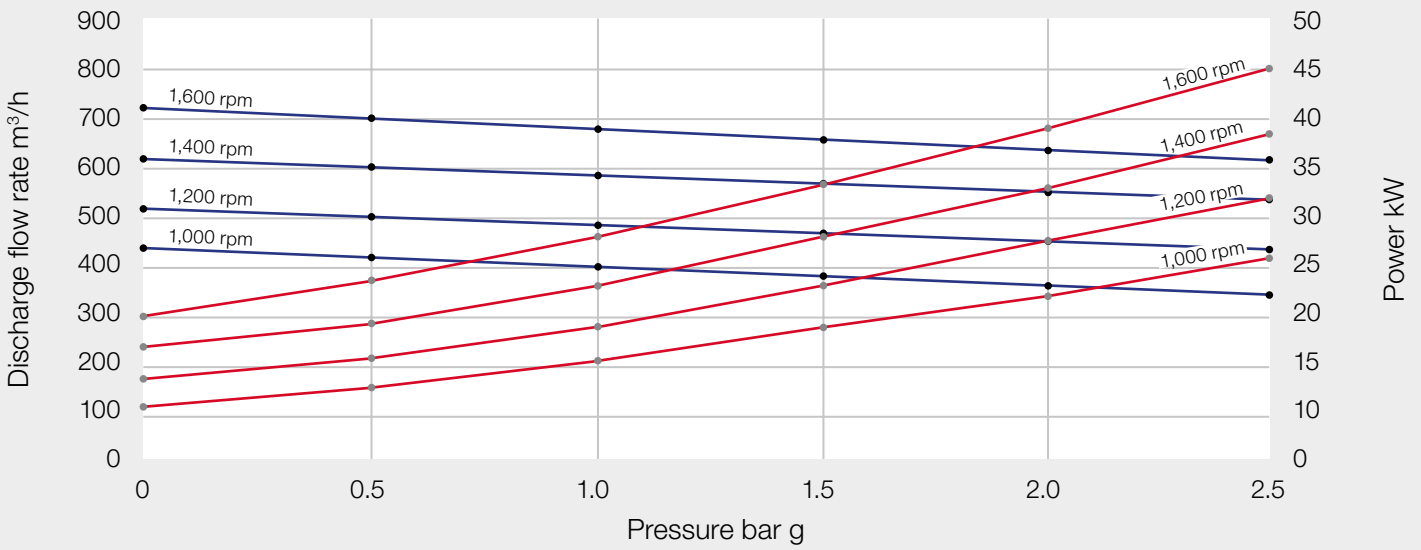

Dimensions

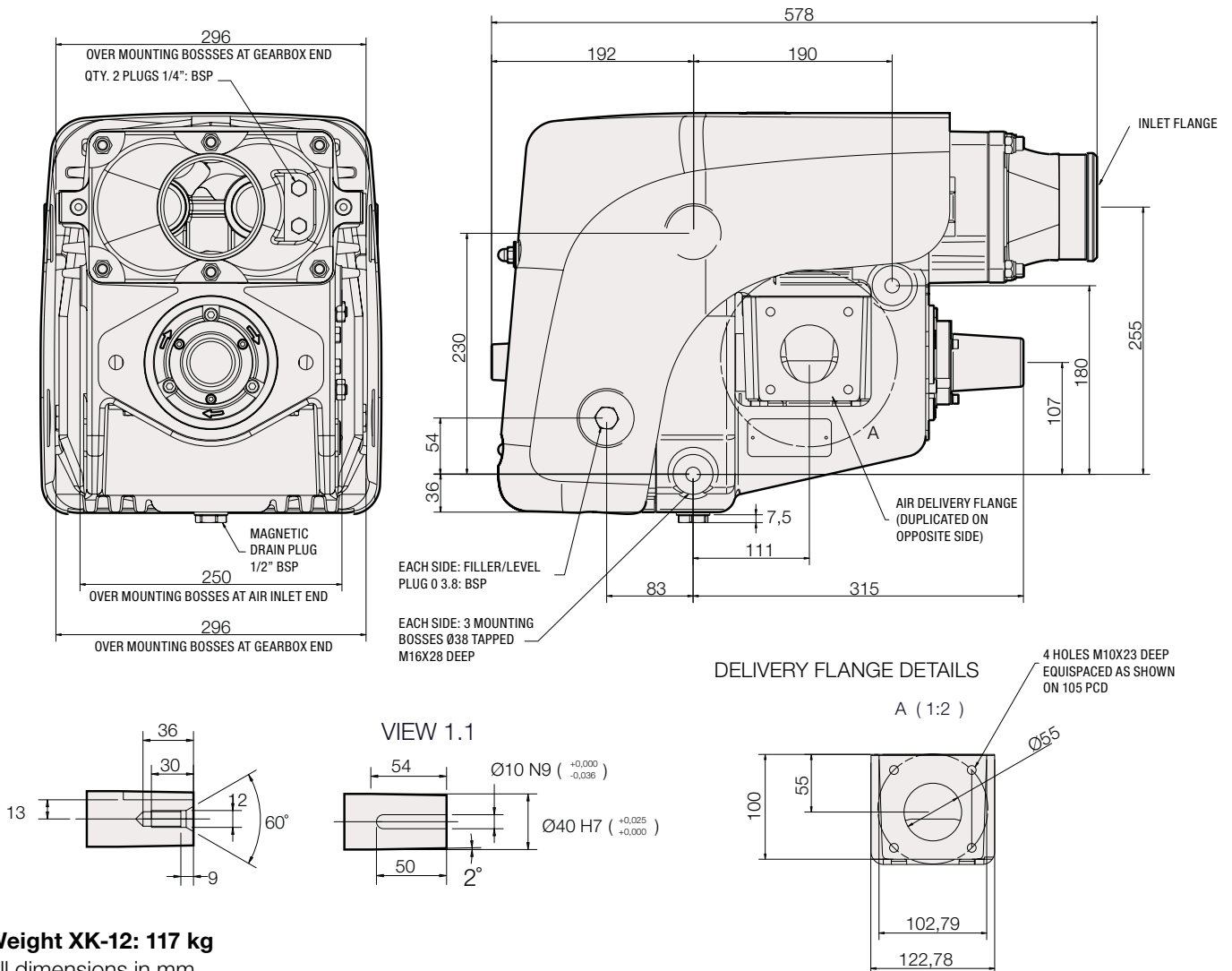

Weight XK-12: 117 kg
All dimensions in mm

XK-18 Compressor

XK|18



Maximum discharge pressure: 2.2 bar g
Discharge flow rate 500 – 1,060 m³/h at 2.2 bar g

Specification

General design

The XK-18 is an oil free screw compressor comprising synchronised screw rotors, combined main body step up gearcase assembly and inlet bearing carrier.

Mounting

The compact shape and size of the XK-18 make it ideal for mounting inside the chassis on most vehicles to enable low cost direct PTO driving.

A through shaft allows CW or ACW input drive rotation with mounting points on either side of the machine to provide further flexibility.

Drive Options

Prop. shaft drive: Direct from a vehicle PTO

Hydraulic drive: Several drives can be offered depending on the application

Electric motor: Packages on base frames utilising the high input speed variant

Engine drive: Packages on base frames utilising the high input speed variant

The Standard Package

The standard package consists of the following equipment:

- Basic XK-18 machine and mounting flange pack
- Inlet kit including a cyclonic inlet filter
- Commissioning filter
- Relief valve
- Check valve and flange pack
- Outlet silencer – reactive or absorptive
- Torque limiting coupling

Note: The machine is also available in a high input speed version (1,800 – 3,260 rpm) for diesel engine and electric motor drives.

Optional Ancillaries

- Various drive flanges
- Absorptive or reactive silencer
- Various flange pack materials
- Remote air cooler pack
- Delivery filter

Air Cooler & Ancillary Package

The air cooler and ancillary package is a modular assembly designed to combine with the XK-12 and XK-18 compressors and supply cool air for discharging products sensitive to high temperature (e.g. sugars and plastics).



XK-12 & XK-18 Cooler Discharge Temperatures

(above the fan & air inlet temperature)

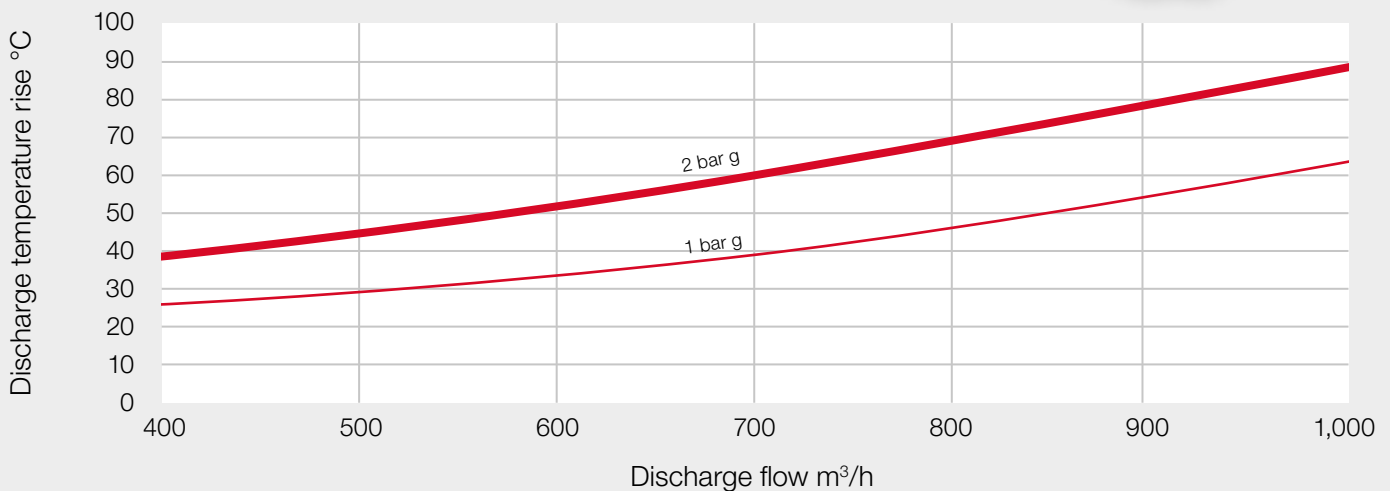

Specification

General design

The air cooler itself comprises a cooling fan, radiator and cooling duct. This is assembled/located inside a GRP enclosure module also housing the inlet filter, filter blockage indicator, relief valve, reactive discharge silencer and check valve.

The electrically operated cooling fan (24V DC) provides a continuously high cooling rate throughout the discharge flow range of the compressor.

Cooling Performance

There are many different factors effecting the best cooling rate, but the maximum temperature rise at 2 bar g should not exceed 89° C above the fan and air inlet temperature throughout the XK-12 and XK-18 operating ranges.

Mounting

The common machine/cooler mounting bracket allows the air cooler to be mounted parallel to the chassis, but also includes provision to alter the drive axis angle of the compressor to match that of the PTO.

The package can be mounted on the left or right hand side of the vehicle chassis with a forward or rearward build and the compressor fitted to offer a CW or ACW input drive rotation (as required).

The Standard Package

The cooler package and bracket will be combined with the compressor prior to despatch to allow the assembly to be lifted out of the box and be fitted directly to the vehicle.

Dimensions

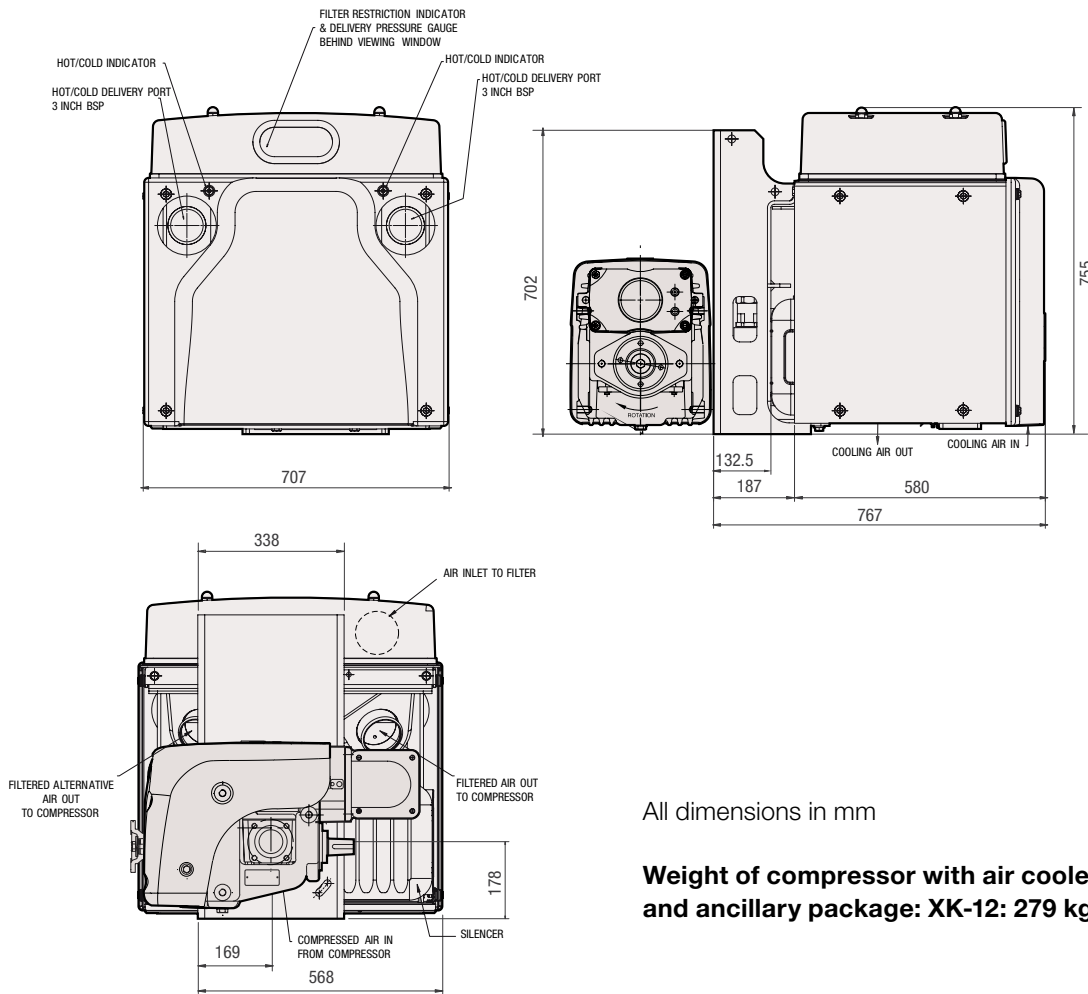

All dimensions in mm

Weight of compressor with air cooler and ancillary package: XK-12: 279 kg · XK-18: 290 kg

Accessories

Remote Air Cooler

The remote air cooler is a modular assembly designed to combine with our range of compressors to supply cool air for discharging products sensitive to high temperature such as sugars and plastics.



Hydrapak

The Hydrapak is a compact, low weight design containing the reservoir, return filter, radiator, cooling fan and system relief valve so that it simply needs to be mounted on the vehicle and connected to the hydraulic system. This reduces significantly the complete system installed weight from that of a traditional oil reservoir (tank).



Micronic Filters

The M329 range of stainless steel discharge filters provide a complete air filtration (5 µm) and condition monitoring system to prevent the contamination/degradation of liquid and dry products (e.g. foods and plastics) in the tanker offloading industry.



Designed for off-loading dry bulk products in the tank truck markets

Pulverants / Powders

- Cement
- Flour
- Lime
- Fly Ash

Granules

- Sugar
- Sand
- Salt
- Pulverised Limestone

Pebble

- Limestone
- Plastic Pellets
- Rocksalt
- Dolomite

Feeds

- Corn
- Rice
- Pelletized Feed
- Soy Beans
- Oats

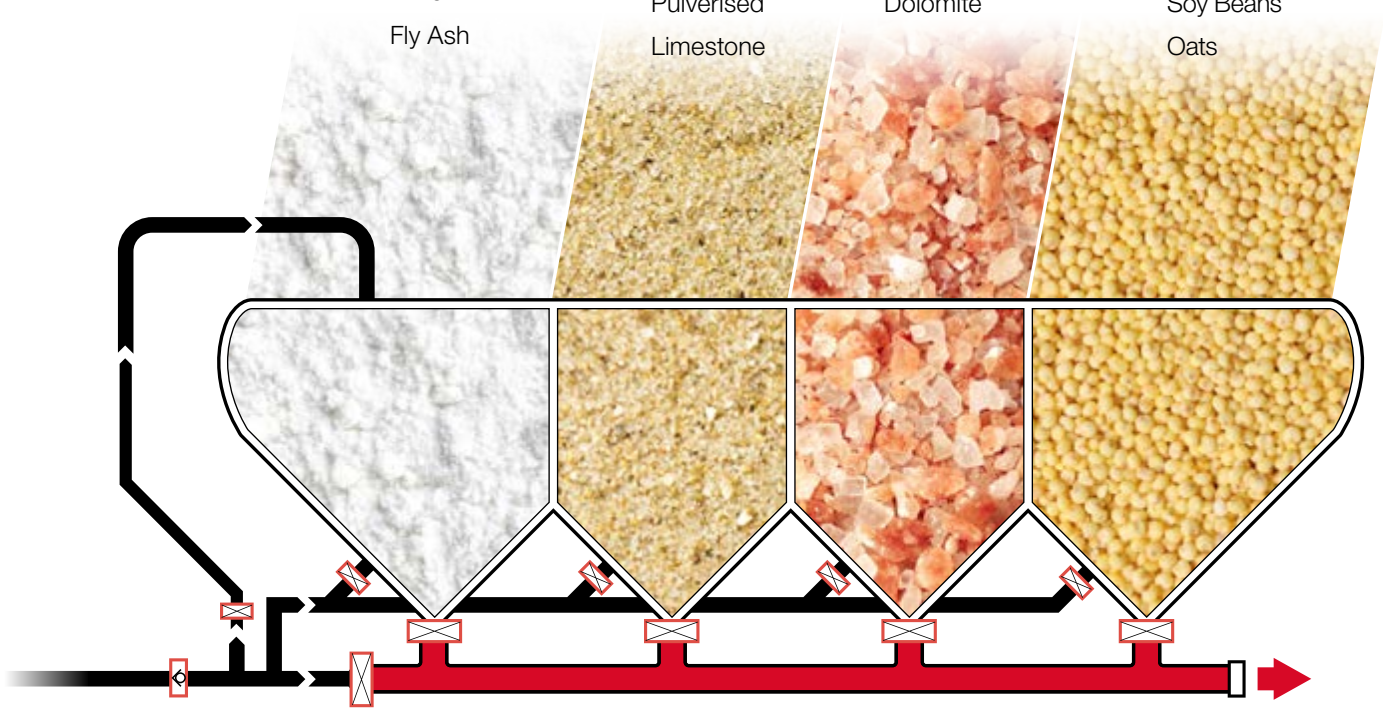

Product Overview Blowers and Compressors for Dry Bulk Transfer



XK-12 and XK-18 Series

- Fan-cooled, oil-free screw rotor compressor, simple and acoustically enclosed packages
- Direct in-chassis, e-motor and engine drive
- Low maintenance, efficient, contaminant-free discharge of bulk powders, granules, pellets and feeds from road tankers using in-chassis direct drives

Flowrate up to 1,068 m³/hr at 2 bar g

Discharge pressure 2.5 bar g for XK-12, 2.2 bar g for XK-18



Bulkline 650 and 1000 Series

- Oil-free, screw rotor compressor in simple and acoustically enclosed packages
- Belt, hydraulic, e-motor and engine drive
- Low maintenance, efficient, contaminant-free discharge of bulk powders, granules, pellets and feeds from road tankers using belt and other drives

Flowrate up to 945 m³/hr at 3,600 rpm, 2.5 bar g



TR20

- DRUM screw compressor
- Shorter loading and unloading times
- Drive located at the back of the machine
- Compact, space-saving design
- For six wheel and short wheel base vehicles

High flowrate of 1,170 m³/hr

Discharge pressure up to 2.2 bar g



T5CDL9, 12 and 13 Series

- Low pressure, oil-free, helical/lobe blower
- Direct, belt, hydraulic, e-motor and engine drive
- Low maintenance, contaminant-free discharge of bulk powders, granules, pellets and feeds from road tankers at up to 1.2 bar g continuously

Flowrate up to 1,500 m³/hr

Discharge pressure up to 1.2 bar g

Ultimate Service Capability

Our customers rely on us day after day to keep their systems running cost-effectively and at optimum performance. We take customer care very seriously and have developed our aftermarket capabilities year on year.

- Custom-engineered and turnkey solutions
- Local service centres
- Factory-trained service engineers
- Worldwide service network

Only genuine spare parts and lubricants are specifically designed to guarantee the reliability, optimum efficiency and performance of Gardner Denver products. Our extensive distribution network and intelligent stocking policies provide excellent availability of genuine spare parts and lubricants.

WITTIG

**Gardner
Denver**

ROBUSCH®

© **hydrovane**

 **SSP
Pumps**

 **SOLIMAR**

DRUM

AIR DRIVE

**Gardner
Denver**

TRANSPORT SOLUTIONS

AUTHORIZED PARTNER

Please contact your Gardner Denver product representative for a Technical Data Sheet or further information on any of these products.

**Gardner
Denver**

TRANSPORT SOLUTIONS

Gardner Denver Transport Solutions

PO Box 178, Springmill Street, Bradford,
West Yorkshire, BD5 7HY, England

Tel.: +44 (0) 1274 683131

Fax: +44 (0) 1274 655272

drumsales@gardnerdenver.com

www.gd-transport.com