

* incl. 20 [-5; +30] mm pull out

3D model is available on request or www.hyva.com

Specifications		Max. pump flow		Tipping time	
Max. working pressure	250 bar	With KO ¹	190 L/min	With KO ¹	16 sec
Weight	237 kg	Without KO ¹	137 L/min	Without KO ¹	23 sec
Working volume	52 L	With KO ¹ below -20°C	133 L/min	With KO ¹ below -20°C	23 sec
Total volume	57 L	Without KO ¹ below -20°C	96 L/min	Without KO ¹ below -20°C	33 sec
Max. cyl. load (start tipping)	245 kN			Allowable lowering time	16 sec

Technical notes

- This cylinder is a lifting device only. • It should not be used as a structural member and should not be subjected to side loads. • Tipping valve must have a pressure relief at the cylinder port set not higher than max. working pressure. • Verify max. cyl. load. • Working temperature range is between -40°C and +80°C. • Max. duration of extension is 0.5 hours (excluded hard chromed stages). • Cylinder is painted black (RAL9005) with a min. thickness conforming to the 480 hours neutral salt spray test as per ISO 9227. • ¹ Hyva knock-off.

Related documentation

- Bracket options: 015BRA10 & 015BRA12
- Mounting instructions: CYL-0030
- Oil specifications: OIL-0011
- Spec sheet explanation: CYL-0041

Configuration

Extension	1	2	3	4	5	6	7	Total
Effective diameter [mm]	149	129	110	91				4420
Stroke* [mm]	1150	1170	1170	930				

Tipping weight

For detailed tipping calculations please refer to: <https://tipper.hyva.com>

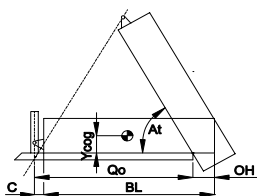

- BL body length
- OH rear overhang vert. pos. centre of gravity
- Ycog of gravity pivot length
- Qo bracket length
- C tipping angle
- At stroke x 60 / Qo

BL [mm]	5900	800	5650	800	5400	800
OH [mm]	200	500	200	500	200	500
At [°]	44	47	46	49	48	51
Ycog [mm]	600	52	60	49	55	51
C	47	52	49	55	51	58
At	51	52	60	49	55	51

Tipping weight [ton] at maximum pressure of 250 bar for a vertically mounted cylinder and C is 229 mm

Pos.	Part no.	Description	Qty.
C01	71839040	DUST COVER FC LOW 15-244	1
C02	71706425	COVER 242-1165 PIN60 A340 FIX	1
C03	01702956K	WASHER M48 DIN 125B ZP	1
C04	01702907K	TOPNUT NYLOC M48x3 DIN 985 ZP	1
P01	74462375	PISTON FL3 S 091-1365-HC (SR=240)	1
P02	71853091K	SLIDER FL 091 (2 X 1/2) A22	1
P03	71851091K	OUTER STOPRING FL 091 A22	1
P04	71822091	BOTTOM PLATE PISTON FL 091	1
P05	01745012K	CIRCLIP 82 DIN 472 (87.5x2.5)	1
P06	71870215K	O-RING PISTON BOTTOM 091	1
P07	71848200	PISTON HEAD FL3 091	1
P08	01226430K	O-RING 72.62 X 3.53 MM	1

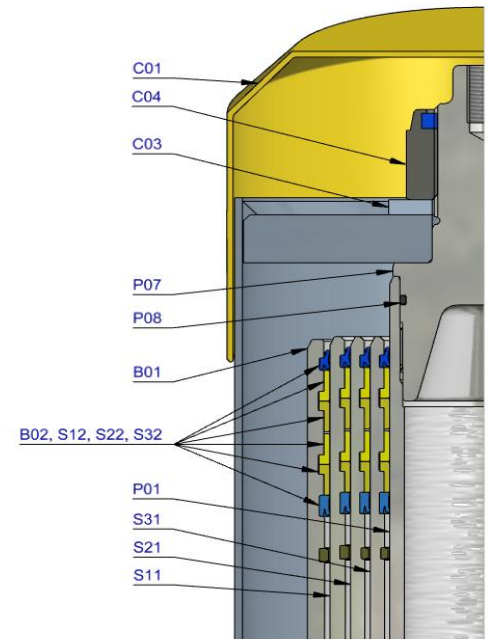

S31	74603370	STAGE FL2 110-1360	1
S32	71802110K	PACKSET FL 110	1
S33	71853110K	SLIDER FL 110 (2 X 1/2) A22	1
S34	71851110K	OUTER STOPRING FL 110 A22	1
S35	71852110K	LIFTRING FL 110 A22	1

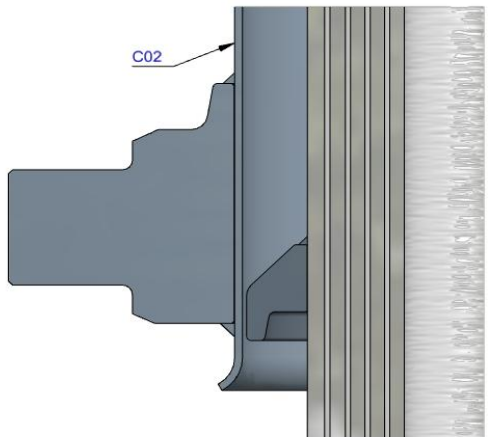

S21	74604370	STAGE FL2 129-1360	1
S22	71802129K	PACKSET FL 129/HP 129	1
S23	71853129K	SLIDER FL 129 (2 X 1/2) A22	1
S24	71851129K	OUTER STOPRING FL 129 A22	1
S25	71852129K	LIFTRING FL 129 A22	1

S11	74605370	STAGE FL2 149-1360	1
S12	71802149K	PACKSET FL 149/HP 150	1
S13	71807151K	SLIDER FL 149 A35	1
S14	71851149K	OUTER STOPRING FL 149 A22	1
S15	71852149K	LIFTRING FL 149 A22	1

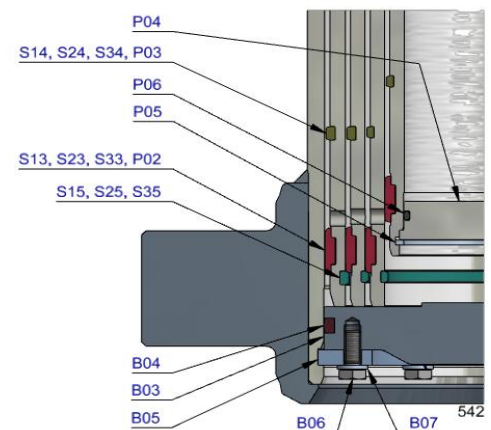

B01	74506372R1065	BASE FL2 169-1399-4/4BSAE-190-90-C242	1
B02	71802169K	PACKSET FL 169	1
B03	71825425	BOTTOM PLATE FL2 169	1
B04	71870035K	SEAL BOTTOM PLATE FL 169	1
B05	71820169	LOCKING PLATE FL 169	3
B06	01732055K	BOLT HEX M8X20X1.25 SET 6 PCS	1
B07	01732559K	WASHER SPRING M8 SET 6 PCS	1

Seal kit complete

71908540K	Consists of all packsets with packset grease and O-rings
-----------	----------------------------------------------------------

Notes

The inner stopring and piston bottom are pre-mounted on spare bases, stage and pistons. Therefore, when ordering new tubes, it is not required to order these parts separately.

For repair instructions see: CYL-0040. Serial no. is located on type plate and near type plate support.